

Card Wrapping Fixture



Card Wrapping Fixture

Two Radius Tests for Module Resistance

Q-Card's wrapping fixture is designed to apply bending stress to a module embedded within a card's body in order to check gluing resistance. The test fixture has the capability to perform at two bending radii: 20mm and 25mm.

The wrapping fixture features a horizontal design with splayed feet and aggressive no-slip rubber pads for stability. It is manufactured of aerospace-grade aluminum alloy with a hard anodized, scratch-resistant, durable finish to provide years of rigorous testing and trouble-free service.

Q-Card's Card Wrapping Fixture is designed to perform this test according to the following standards:

Mastercard CQM

Ordering Details

Part #	Description
906710	Wrapping Test Fixutre

Specifications

Weight

- 2.5 lbs.

Dimensions

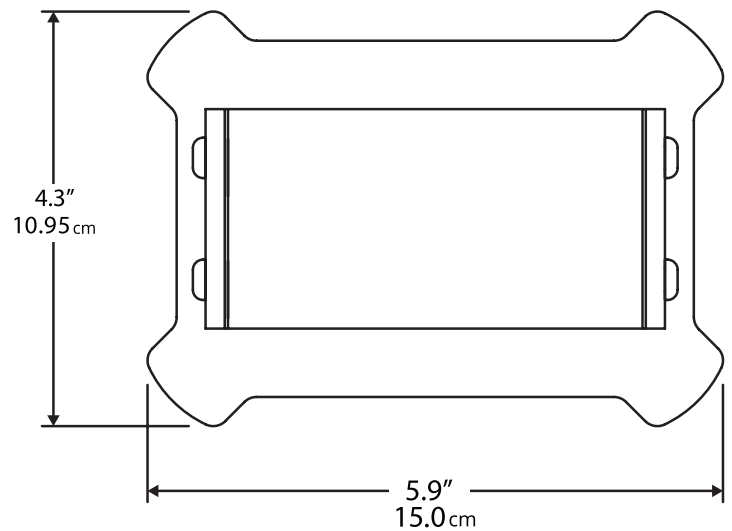
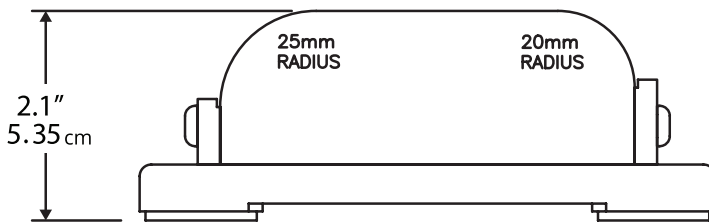

301 Reagan Street
Sunbury PA 17801 USA
Phone 570.286.7447
Fax 570.286.2649
www.q-card.com



800-717-8007